

Yale Robotics

MOT series

5,000kg / 7,000kg

Yale[®]
People. Products. Productivity.[™]

Tow Tractor



- Robotic and manual dual-mode operation
- CAN bus technology
- Standard trailer handling configurations
- Horizontal transport over short and long distances

Truck Dimensions

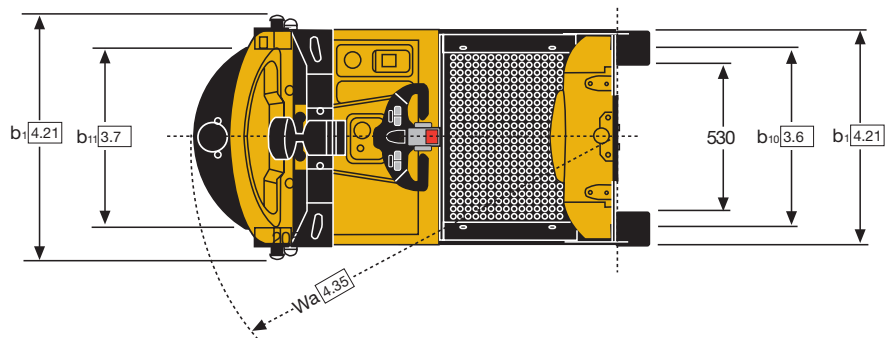
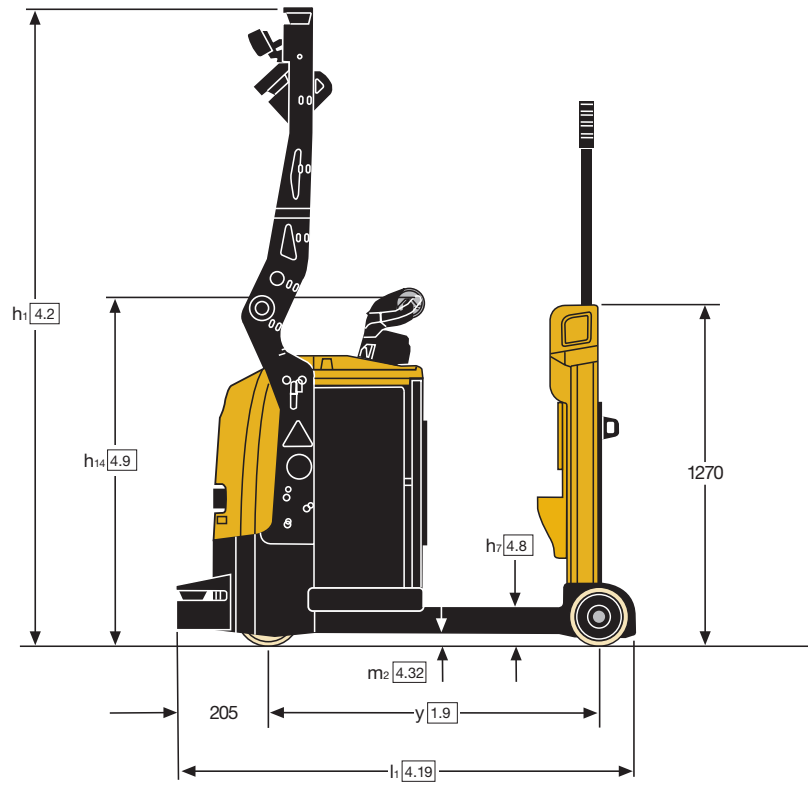

VDI 2198 – General Specifications

Distinguishing mark	1.1	Manufacturer (abbreviation)		Yale	Yale
	1.2	Manufacturer's type designation		MO50T	MO70T
	1.3	Drive: electric (battery or mains), diesel, petrol, fuel gas		Electric (battery)	Electric (battery)
	1.4	Operator type: hand, pedestrian, standing, seated, tow tractor		Tow tractor	Tow tractor
	1.5	Rated capacity/Rated load	Q (t)	5.0	7.0
	1.7	Rated drawbar pull	F(N)	1000	1336
Weights	1.9	Wheelbase	y (mm)	1229 ⁽¹⁾	1229 ⁽¹⁾
	2.1	Service weight	kg	1136 ⁽¹⁾	1236
Tyres/chassis	2.3	Axle loading, unladen front/rear	kg	699 / 437	694 / 542
	3.1	Tyres: polyurethane, tophane, vulkollan, front/rear		Vulkollan / Polyurethane	Tophane / Polyurethane
	3.2	Tyre size, front	ø (mm x mm)	254 x 90	254 x 90
	3.3	Tyre size, rear	ø (mm x mm)	200 x 100	200 x 100
	3.5	Wheels, number front/rear (x = driven wheels)		1 x /2	1 x /2
	3.7	Tread, rear	b ₁₁ (mm)	686	686
Dimensions	4.2	Height	h ₁ (mm)	2485	2485
	4.8	Seat height relating to SIP/stand height	h ₇ (mm)	152	152
	4.9	Height drawbar in driving position min./max.	h ₁₄ (mm)	1317	1317
	4.12	Coupling height	h ₁₀ (mm)	365	365
	4.17	Overhang	l ₅ (mm)	135	135
	4.19	Overall length	l ₁ (mm)	1705	1705
	4.21	Overall width	b ₁ /b ₂ (mm)	925	925
	4.32	Ground clearance, center of wheelbase	m ₂ (mm)	50	50
	4.35	Turning radius	Wa (mm)	1434 ⁽¹⁾	1434 ⁽¹⁾
Performance data	5.1	Travel speed, laden/unladen	km/h	5.4	5.4
	5.5	Drawbar pull, laden/unladen	N	1000	1336
	5.6	Max drawbar pull, laden/unladen	N	3000	4500
	5.8	Max. gradeability, laden/unladen	%	3 / 3	3 / 3
	5.10	Service brake		Electromagnetic	Electromagnetic
Electric engine	6.1	Drive motor, S2 60 min rating	kW	2.6	3
	6.3	Battery according to DIN 43531/35/36 A,B,C, DS		no	no
	6.4	Battery voltage/nominal capacity K5	(V)/(Ah)	24 / 620 ⁽¹⁾	24 / 620 ⁽¹⁾
	6.5	Battery weight	kg	480	480
	6.6	Energy consumption according to VDI cycle ⁽²⁾	kWh/h at no. of cycles	1.82	2.37
	8.1	Type of drive unit		AC-Controller Automation driven by Baylo	AC-Controller Automation driven by Baylo
10.7	Sound pressure level at the driver's seat	dB (A)	< 65	< 65	

⁽¹⁾ Available battery 465Ah. With battery 465Ah -145mm, and service weight -114kg

⁽²⁾ Values obtained with 40 cycles

All values are nominal values and they are subject to tolerances. For further information, please contact the manufacturer.

Yale products might be subject to change without notice

Lift trucks illustrated may feature optional equipment.

Values may vary with alternative configurations.

MOT series

Models: MO50T, MO70T



Robotics

This truck has Yale robotics fitted. Our solutions are based on the established Yale manual truck range. This dual-mode design provides both flexibility of operation and simplicity of servicing, with our authorised dealer network already familiar with 90% of the mechanical and electrical systems of each robotic unit. For pre-sales support, warehouse systems specialists are available to visit potential sites to collect data and suggest solutions where required.

Tow Tractor

Designed for use in a wide range of manufacturing applications, particularly for line-feed operations

Productivity

- The powerful high thermal capacity 2.6kW or 3kW AC drive motor delivers high performance acceleration, braking and travel speed, making these models ideal for stop and go operations.
- A maximum travel speed of 13km/h reduces travel time on long runs between docking and picking areas

Cost of Ownership

- The utilisation of a standard truck with the modularity of the robotic components ensures that dealer technicians are familiar with every aspect of the vehicle
- Established, proven platform
- Adjustable performance settings allow the truck to be tailored to the needs of the application, reducing energy consumption
- Regenerative braking reduces the use of the service brake and dissipates heat from the traction motor increasing the life of key components
- Motors and controllers are protected against damage and debris, reducing servicing and repair costs

- The dual-mode capability makes the requirement for additional trucks redundant.

Dependability

- The solid frame construction and industrial grade components ensure long-term reliability and durability
- A sturdy wrap around bumper plate protects the truck against impacts and damage and minimises repair costs
- The truck's electronics - including the enclosed AC traction motor, sealed combi-controller (with IP65 rating), sealed electrical connectors and Hall effect sensors and switches - are all protected from damage to ensure excellent reliability, maximum productivity and reduced servicing costs
- Reduced wiring complexity is a result of the CANbus communication system, which also provides easy access to components and delivers excellent reliability.

Serviceability

- CAN bus systems allow quick and simple diagnostics of truck and system
- Fault code can displayed on the touch-screen console and notifications can alert the traffic management system
- Full access to all the trucks main components, including the motor, is by the removal of the motor cover, which is retained by two easily removed screws.

Available Options include:

- Side battery extraction
- Several hook types
- Various drive wheel compounds.

HYSTER-YALE UK LIMITED

trading as **Yale Europe Materials Handling**
Centennial House, Frimley Business Park,
Frimley, Surrey GU16 7SG, United Kingdom.

Tel: +44 (0) 1276 538500



Fax: +44 (0) 1276 538559

www.yale-forklifts.eu



Publication part no. 220990698 Rev.00 Printed in The Netherlands (1018HG) EN.

Safety: This truck conforms to the current EU requirements. Specification is subject to change without notice.

Yale, VERACTOR and  are registered trademarks. "PEOPLE, PRODUCTS, PRODUCTIVITY", PREMIER, Hi-Vis, and CSS are trademarks in the United States and certain other jurisdictions. MATERIALS HANDLING CENTRAL and MATERIAL HANDLING CENTRAL are Service Marks in the United States and certain other jurisdictions.  is a Registered Copyright.
©Yale Europe Materials Handling 2018. All rights reserved. Truck shown with optional equipment.
Country of Registration: England and Wales. Company Registration Number: 02636775