



**STRONG PARTNERS.
TOUGH TRUCKS.™**

FORTENS™



H8.0-9.0FT SERIES TECHNICAL GUIDE



WWW.HYSTER.COM

> DIMENSIONS

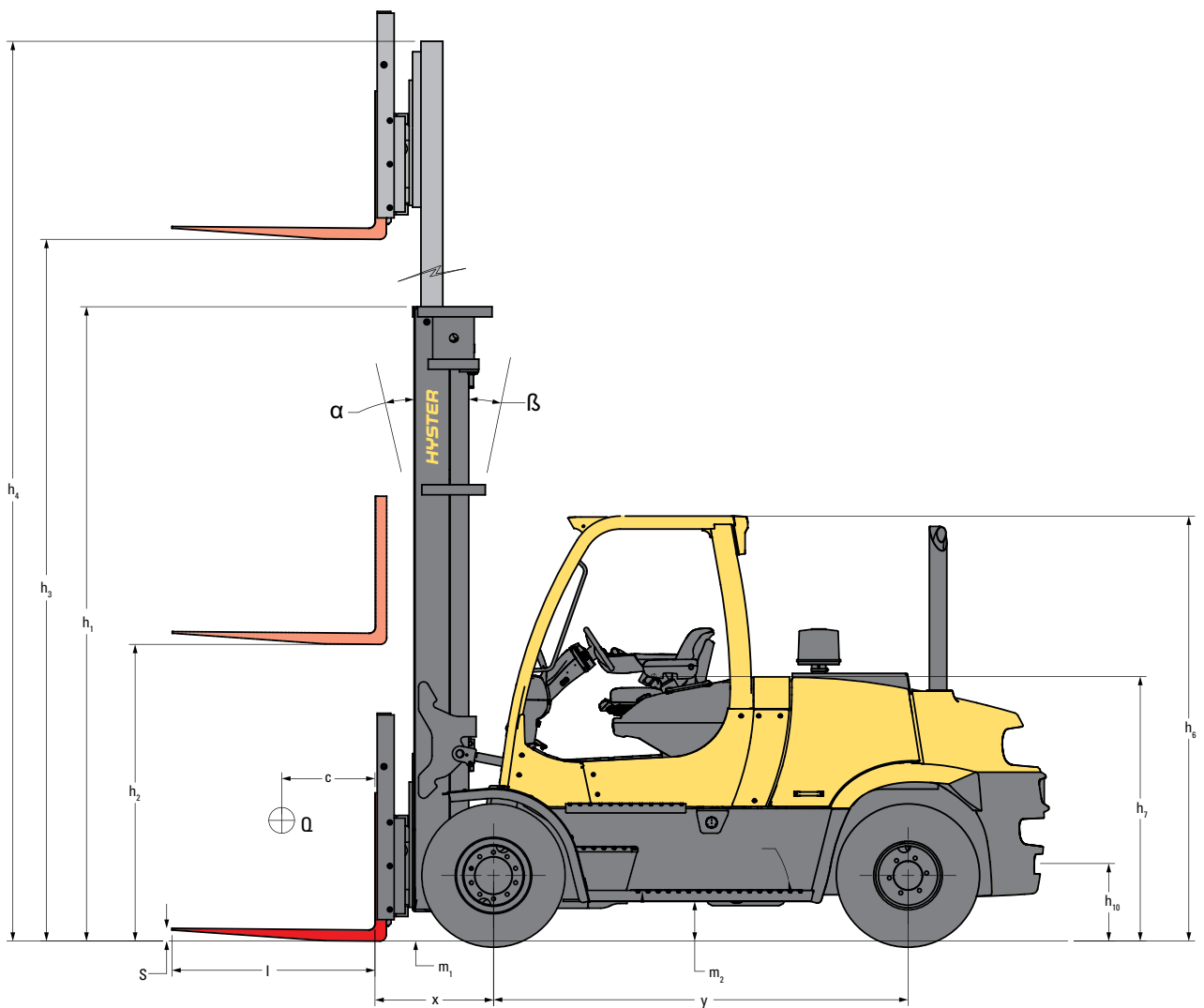
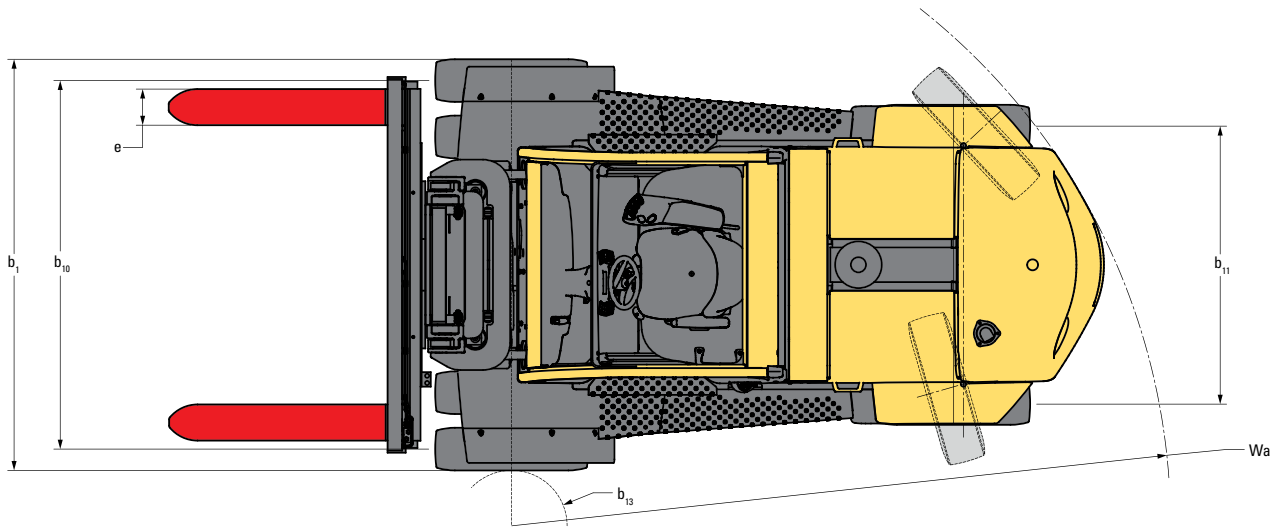

H8.0FT9 RATED CAPACITY KG@ 900 MM LOAD CENTRE

	Maximum fork height h ₃ + s (mm)	Back tilt (°)	Lowered height h ₁ (mm)	Extended height h ₄ (mm) (1)	Free lift height h ₂ + s (m)	8.25 x 15-14 Dual pneumatic drive tyres					
						Carriage without sideshift (kg)		Carriage without sideshift (kg)		Carriage with integral sideshift and fork positioner (kg)	
						H8.0FT9		H8.0FT9		H8.0FT9	
						Capacity at Max height	Capacity to lift height	Capacity at Max height	Capacity to lift height	Capacity at Max height	Capacity to lift height
2-STAGE LIMITED FREE LIFT	3065	9°	2712	4398	0	8000		7580		7550	
	3565	9°	2962	4898	0	8000		7560		7530	
	4565	9°	3462	5898	0	8000		7530		7500	
	5565	9°	3962	6898	0	7920	8000 kg to 5265 mm lift	7420	7500 kg to 5265 mm lift	7390	7460 kg to 5265 mm lift
	6065	9°	4212	7398	0	7770	8000 kg to 5265 mm lift	7270	7480 kg to 5265 mm lift	7240	7440 kg to 5265 mm lift
3-STAGE FULL FREE LIFT	4615	6°	2712	6125	1405 (2)	8000		7560		7530	
	5515	6°	3012	7025	1705 (2)	7770	8000 kg to 4615 mm lift	7320	7530 kg to 4615 mm lift	7290	7500 kg to 4615 mm lift
	5965	6°	3162	7475	1855 (2)	7650	8000 kg to 4615 mm lift	7180	7510 kg to 4615 mm lift	7150	7480 kg to 4615 mm lift

H9.0FT6 RATED CAPACITY KG@ 600 MM LOAD CENTRE

	Maximum fork height h ₃ + s (mm)	Back tilt (°)	Lowered height h ₁ (mm)	Extended height h ₄ (mm) (1)	Free lift height h ₂ + s (m)	8.25 x 15-14 Dual pneumatic drive tyres					
						Carriage without sideshift (kg)		Carriage without sideshift (kg)		Carriage with integral sideshift and fork positioner (kg)	
						H9.0FT6		H9.0FT6		H9.0FT6	
						Capacity at Max height	Capacity to lift height	Capacity at Max height	Capacity to lift height	Capacity at Max height	Capacity to lift height
2-STAGE LIMITED FREE LIFT	3065	9°	2712	4350	0	9000		8500		8460	
	3565	9°	2962	4850	0	9000		8490		8440	
	4565	9°	3462	5850	0	9000		8470		8420	
	5565	9°	3962	6850	0	8720	8000 kg to 5265 mm lift	8190	7500 kg to 5265 mm lift	8140	7460 kg to 5265 mm lift
	6065	9°	4212	7350	0	8120	8000 kg to 5265 mm lift	7620	7480 kg to 5265 mm lift	7570	7440 kg to 5265 mm lift
3-STAGE FULL FREE LIFT	4615	6°	2702	6077	1565 (2)	9000		8500		8470	
	5515	6°	3002	6977	1865 (2)	8830	8000 kg to 4615 mm lift	8320	7530 kg to 4615 mm lift	8290	7500 kg to 4615 mm lift
	5965	6°	3152	7427	2015 (2)	8300	8000 kg to 4615 mm lift	7810	7510 kg to 4615 mm lift	7780	7480 kg to 4615 mm lift

NOTES:

Specifications are affected by the condition of the vehicle and how it is equipped, as well as the nature and condition of the operating area. Inform your dealer of the nature and condition of the intended operating area when purchasing your Hyster® truck.

- (1) Top of forks.
- (2) W/o load backrest.
- (3) h6 subject to +/- 5 mm tolerance. 2549mm for Cab option.
- (4) Full suspension seat in depressed position.
- (5) Add 32mm with load backrest.
- (6) Variable.
- (7) Measured according to the test cycles and based on the weighting values contained in EN12053.

All capacities are according to EN1551.

MAST TABLES:

- (1) Deduct 224 with load backrest
- (2) Add 224 without load backrest
- (3) Deduct 125 without load backrest
- (4) Add 125 without load backrest

Safety: This truck conforms to the current EU and ANSI requirements.

NOTICE:

Care must be exercised when handling elevated loads. Operators must be trained and must read, understand and follow the instructions contained in the Operating Manual.

All values are nominal values and they are subject to tolerances. For further information, please contact the manufacturer.

Hyster products are subject to change without notice.

Lift trucks illustrated may feature optional equipment. Values may vary with alternative configurations.

CERTIFICATION: Hyster lift trucks meet the design and construction requirements of B56.1-1969, per OSHA Section 1910.178(a)(2), and also comply with the B56.1 revision in effect at time of manufacture. Certification of compliance with the applicable ANSI standards appears on the lift truck. Performance specifications are for a truck equipped as described under Standard Equipment on this Technical Guide. Performance specifications are affected by the condition of the vehicle and how it is equipped, as well as by the nature, condition of the operating area, proper service and maintenance of the vehicle. If these specifications are critical, the proposed application should be discussed with your dealer.

NOTE: Specifications, unless otherwise listed, are for a standard truck without optional equipment.

Specification data is based on VDI 2198.

> H8.OFT9 SPECIFICATIONS

			HYSTER			HYSTER			HYSTER					
			H8.OFT9			H8.OFT9			H8.OFT9					
GENERAL	1-1	Manufacturer			HYSTER			HYSTER			HYSTER			
	1-2	Model designation			H8.OFT9			H8.OFT9			H8.OFT9			
		Model			FORTENS™ Advance			FORTENS™ Advance			FORTENS™ Advance			
		Engine			GM 5.7L			Kubota 3.8L 55kW			Kubota 3.8L 82kW			
		Transmission			DuraMatch™ 3			DuraMatch™ 3			DuraMatch™ 3			
					3-speed			3-speed			3-speed			
	1-3	Powertrain / drivetrain			LPG			Diesel			Diesel			
	1-4	Operator type			Seated			Seated			Seated			
	1-5	Rated capacity / rated load	Q	kg	8,000			8,000			8,000			
1-6	Load centre distance	c	mm	900			900			900				
1-8	Load distance	x	mm	613.5			613.5			613.5				
1-9	Wheelbase	y	mm	2,450			2,450			2,450				
WEIGHT	2-1	Service weight			12,417			12,417			12,417			
	2-2	Axle loading with load, front / rear			kg	18,470	5,365	18,470	5,365	18,470	5,365			
	2-3	Axle loading without load, front / rear			kg	1,947	7,052	1,947	7,052	1,947	7,052			
WHEELS	3-1	Tyre type			Pneumatic			Pneumatic			Pneumatic			
	3-2	Tyre size, front			8.25x15 14PR			8.25x15 14PR			8.25x15 14PR			
	3-3	Tyre size, rear			8.25x15 14PR			8.25x15 14PR			8.25x15 14PR			
	3-5	Wheels, number front / rear (x = driven wheels)			x4	2	x4	2	x4	2	x4	2		
	3-6	Tread, front	b ₁₀	mm	2,003			2,003			2,003			
	3-7	Tread, rear	b ₁₁	mm	1,535			1,535			1,535			
	4-1	Mast tilt, forward / backward	α/β	deg	5°	9°	5°	9°	5°	9°	5°	9°		
4-2	Height, mast lowered	h ₁	mm	2,712			2,712			2,712				
4-3	Free lift (1)	h ₂	mm	105			105			105				
4-4	Lift (1)	h ₃	mm	3,065			3,065			3,065				
4-5	Height, mast extended (2)	h ₄	mm	4,239			4,239			4,239				
4-7	Height of overhead guard (cabin) (3)	h ₆	mm	2,531			2,531			2,531				
4-8	Seat height to SIP (4)	h ₇	mm	1,558			1,558			1,558				
4-12	Coupling height	h ₁₀	mm	474			474			474				
4-19	Overall length	l ₁	mm	5,238			5,238			5,238				
4-20	Length to face of forks	l ₂	mm	4,038			4,038			4,038				
4-21	Overall width	b ₂	mm	2,239			2,239			2,239				
4-22	Fork dimensions ISO 2331	s/e/l	mm	60	150	1,200	60	150	1,200	60	150	1,200		
4-23	Fork carriage type			IV A			IV A			IV A				
4-24	Fork carriage width (5)	b ₃	mm	2,030			2,030			2,030				
4-31	Ground clearance, laden, below mast	m ₁	mm	173			173			173				
4-32	Ground clearance, centre of wheelbase	m ₂	mm	253			253			253				
4-34-1	Aisle width with pallets 1 000 long x 1 200 crossways	Ast	mm	5,607.5			5,607.5			5,607.5				
4-34-2	Aisle width with pallets 800 wide x 1 200 crossways	Ast	mm	5,807.5			5,807.5			5,807.5				
4-35	Outside turning radius	W _a	mm	3,794			3,794			3,794				
4-36	Internal turning radius	b ₁₃	mm	362			362			362				
PERFORMANCE	5-1	Travel speed, with / without load			km/h	21.4	22.4	21.4	22.4	21.4	22.4			
	5-2	Lifting speed, with / without load			m/s	0.39	0.41	0.31	0.37	0.39	0.41			
	5-3	Lowering speed with / without load			m/s	0.41	0.37	0.41	0.37	0.41	0.37			
	5-5	Drawbar pull, with / without load			N	53,379	31,568	52,570	31,568	53,379	31,568			
	5-7	Gradeability, with / without load			%	27	26	26	26	27	26			
	5-9	Acceleration time, with / without load			sec	On request			On request			On request		
	5-10	Service brake				Hydraulic			Hydraulic			Hydraulic		
	7-5	Fuel consumption according to VDI cycle				10.4			10.4			11.2		

H9.OFT6 SPECIFICATIONS



			HYSTER		HYSTER		HYSTER					
			H9.OFT6		H9.OFT6		H9.OFT6					
GENERAL	1-1	Manufacturer			HYSTER		HYSTER					
	1-2	Model designation			H9.OFT6		H9.OFT6					
		Model			FORTENS™ Advance		FORTENS™ Advance		FORTENS™ Advance			
		Engine			GM 5.7L		Kubota 3.8L 55kW		Kubota 3.8L 82kW			
		Transmission			DuraMatch™ 3		DuraMatch™ 3		DuraMatch™ 3			
					3-speed		3-speed		3-speed			
	1-3	Powertrain / drivetrain			LPG		Diesel		Diesel			
	1-4	Operator type			Seated		Seated		Seated			
	1-5	Rated capacity / rated load	Q	kg	9,000		9,000		9,000			
1-6	Load centre distance	c	mm	900		900		900				
1-8	Load distance	x	mm	613.5		613.5		613.5				
1-9	Wheelbase	y	mm	2,450		2,450		2,450				
WEIGHT	2-1	Service weight			11,956		11,956		11,956			
	2-2	Axle loading with load, front / rear			18,798	5,340	18,798	5,340	18,798	5,340		
	2-3	Axle loading without load, front / rear			2,158	6,616	2,158	6,616	2,158	6,616		
WHEELS	3-1	Tyre type			Pneumatic		Pneumatic		Pneumatic			
	3-2	Tyre size, front			8.25x15 14PR		8.25x15 14PR		8.25x15 14PR			
	3-3	Tyre size, rear			8.25x15 14PR		8.25x15 14PR		8.25x15 14PR			
	3-5	Wheels, number front / rear (x = driven wheels)			x4	2	x4	2	x4	2		
	3-6	Tread, front	b ₁₀	mm	2,003		2,003		2,003			
	3-7	Tread, rear	b ₁₁	mm	1,535		1,535		1,535			
	4-1	Mast tilt, forward / backward	α/β	deg	5°	9°	5°	9°	5°	9°		
4-2	Height, mast lowered	h ₁	mm	2,712		2,712		2,712				
4-3	Free lift (1)	h ₂	mm	105		105		105				
4-4	Lift (1)	h ₃	mm	3,065		3,065		3,065				
4-5	Height, mast extended (2)	h ₄	mm	4,239		4,239		4,239				
4-7	Height of overhead guard (cabin) (3)	h ₆	mm	2,531		2,531		2,531				
4-8	Seat height to SIP (4)	h ₇	mm	1,558		1,558		1,558				
4-12	Coupling height	h ₁₀	mm	474		474		474				
4-19	Overall length	l ₁	mm	5,238		5,238		5,238				
4-20	Length to face of forks	l ₂	mm	4,038		4,038		4,038				
4-21	Overall width	b ₂	mm	2,239		2,239		2,239				
4-22	Fork dimensions ISO 2331	s/e/l	mm	60	150	1,200	60	150	1,200	60	150	1,200
4-23	Fork carriage type			IV A		IV A		IV A				
4-24	Fork carriage width (5)	b ₃	mm	2,030		2,030		2,030				
4-31	Ground clearance, laden, below mast	m ₁	mm	173		173		173				
4-32	Ground clearance, centre of wheelbase	m ₂	mm	253		253		253				
4-34-1	Aisle width with pallets 1 000 long x 1 200 crossways	Ast	mm	5,607.5		5,607.5		5,607.5				
4-34-2	Aisle width with pallets 800 wide x 1 200 crossways	Ast	mm	5,807.5		5,807.5		5,807.5				
4-35	Outside turning radius	W _a	mm	3,794		3,794		3,794				
4-36	Internal turning radius	b ₁₃	mm	362		362		362				
PERFORMANCE	5-1	Travel speed, with / without load			21.4	22.4	21.4	22.4	21.4	22.4		
	5-2	Lifting speed, with / without load			0.43	0.45	0.19	0.42	0.43	0.45		
	5-3	Lowering speed with / without load			0.41	0.37	0.41	0.37	0.41	0.37		
	5-5	Drawbar pull, with / without load			N	53,379	31,421	52,668	31,421	53,379	31,421	
	5-7	Gradeability, with / without load			%	27	27	25	27	27	27	
	5-9	Acceleration time, with / without load			sec		On request		On request			
	5-10	Service brake			Hydraulic		Hydraulic		Hydraulic			
	7-5	Fuel consumption according to VDI cycle			10.7		10.7		11.5			

> POWERTRAINS

GENERAL	1-1	Manufacturer			HYSTER	HYSTER	HYSTER
	1-2	Model designation			H8.0-9.0FT	H8.0-9.0FT	H8.0-9.0FT
	1-3	Powertrain / drivetrain			LPG	Diesel	Diesel

ENGINE	7-1	Engine manufacturer / model			GM 5.7L 99KW	KUBOTA V3800 55KW	KUBOTA V3800 82KW
	7-1a	EPA / CE compliance			Stage V	Stage V	Stage V
	7-2	Engine power output according to ISO 1585	kW		99	55	82
	7-3	Rated speed	min ⁻¹		2,400	2,200	2,400
	7-3-1	Engine torque @rpm (1/min)	Nm/min ⁻¹		422@1600	308@1400	373@1600
	7-4	Number of cylinders / displacement	# / cm ³		8 5735	4 3769	4 3769
	7-10	Battery voltage, rated capacity	V / Ah		12 210	12 210	24 210

DRIVE	8-1	Drive control / Transmission	Type / #	Hydrodynamic transmission		
	8-2	Transmission manufacturer / type	Type / #	DANA		
	8-6	Wheel drive / drive axle manufacturer / type	Type / #	DANA		
	8-11	Service brake	Type	Hydraulic		
	8-12	Parking brake	Type	Hand lever		

MISC	10-1	Operating pressure for attachments	bar	155		155	
	10-2	Oil volume for attachments (6)	l/m	93		93	
	10-3	Hydraulic tank capacity	l	71.7		71.7	
	10-4	Fuel tank capacity	l	74.8		74.8	
	10-7	Sound pressure level at driver's seat (without / with cab) (7)	Lpaz dB(A)	82	79	79	79
	10-7-1	Sound power level during the working cycle (7)	Lwaz dB	103		98	
	10-7	Towing coupling, model / type		Yes / Pin		Yes / Pin	

> RATED CAPACITIES

STANDARD HOOK CARRIAGE

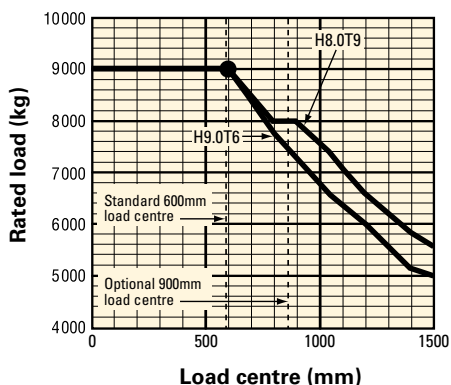

INTEGRAL SIDESHIFT HOOK CARRIAGE

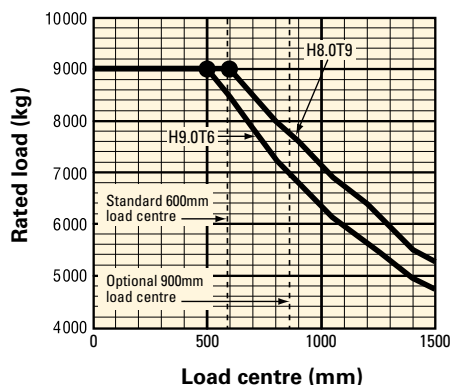

INTEGRAL SIDESHIFT FORK POSITIONER HOOK CARRIAGE

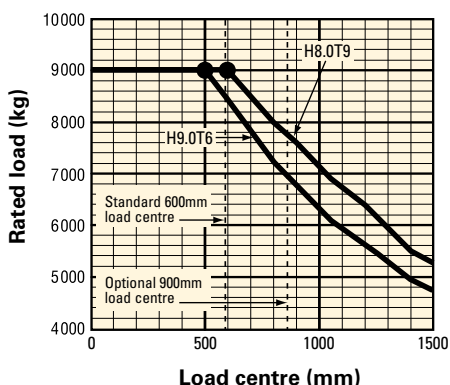

Load centre: Distance from front of forks to centre of gravity of load.

Rated load: Based on vertical 2-stage masts up to 4565mm. Special forks with higher load ratings may be needed to obtain full rating with load centres > 1100 mm

FEATURES AND OPTIONS



PERFORMANCE	STD	OPT
Kubota 3.8L (55kW) - Stage V engine (diesel)	X	
Kubota 3.8L (82kW) - Stage V engine (diesel)		X
GM 5.7L - Stage V engine (lpg)		X
Powertrain Protection System with engine shutdown		X
High air intake with precleaner	X	
Upswept exhaust	X	
Horizontal Exhaust with Catalytic Converter	X	
DuraMatch™ 3 speed transmission		X
Oil-immersed brakes	X	
DRIVE	STD	OPT
Traction speed limiter pre-set to 13km/h (adjustable)		X
Multiple traction speed limit 13/6 km/h		
Multiple traction speed limit 13/8 km/h		X
Multiple traction speed limit 13/10 km/h		X
Traction speed limit with carriage raised (500mm)		X
8.25 x 15-14 Pneumatic Drive Tyres (dual tread)	X	
8.25 R15 Pneumatic Radial Drive Tyres (dual tread)		X
300 x 15 Pneumatic Shaped Solid Drive Tyres (Dual Tread)		X
300 x 15 Non-Marking Pneumatic Shaped Solid Drive Tyres (Dual Tread)		X
8.25 x 15-14 Pneumatic Steer Tyres	X	
8.25 R15 Pneumatic Radial Steer Tyres		X
300 x 15 Pneumatic Shaped Solid Steer Tyres		X
300 x 15 Non-Marking Pneumatic Shaped Solid Steer Tyres		X
LIFT	STD	OPT
Auto speed hydraulics		X
2 Stage limited free lift mast	X	
3 Stage full free lift mast		X
5° Forward / 9° Back Mast Tilt	X	
5° Forward / 6° Back Mast Tilt		X
9° Forward / 5° Back Mast Tilt		X
Hydraulic accumulator		X
HANDLING	STD	OPT
2030mm Hook Type Carriage	X	
2030mm Integral Side Shift Carriage		X
2030mm Integral Side Shift Carriage with Fork Positioner		X
2030mm Integral Side Shift Carriage with Fork Positioner		X
Base Carriage for Integral Attachment		X
1220mm High Load Backrest	X	
1200 x 200 x 65mm Hook Type Forks	X	
Different other type forks		X
ERGONOMICS	STD	OPT
2531mm overhead guard	X	
Operator pre-shift electronic checklist		X
Full steel cab		X
Full steel cab with air conditioning		X
Full suspension vinyl seat	X	
Full suspension swivel vinyl seat		X
Full suspension cloth seat		X
Full suspension cloth swivel seat		X
Full suspension vinyl seat with high backrest lumbar support and headrest		X
Full suspension cloth seat with high backrest lumbar support and headrest		X
Grammer air suspension vinyl seat		X
Grammer air suspension cloth seat		X
Standard seat belt	X	
HI VIS red seat belt		X
HI VIS red seat belt with interlock		X
Air conditioning		X
Dash mounted 12V auxiliary power outlet		X
Steering Wheel with Spinner Knob	X	
TouchPoint™ mini lever hydraulic controls	X	
Joystick		X
Directional lever	X	
Integrated directional switch		X
MONOTROL™		X
Load weight display		X

VISIBILITY	STD	OPT
Dual mirrors side view		X
Rear mounted color camera with LCD display		X
2 front and 1 rear LED work lights with stop, tail, indicator & reverse lights		X
2 front and 1 rear halogen work lights with stop, tail, indicator & reverse lights	X	
LED work light protection		X
Mast mounted LED lights		X
Hazard warning lights		X
OPERATION	STD	OPT
Acme Screw Connector (Non German, UK)		X
Union Nut with Handle Connector (German, Balkans, Austria)		X
Counterweight Mounted LPG Bracket		X
Sealed Alternator		X
Audible reverse alarm		X
Amber strobe light		X
Pedestrian awareness light (P.A.L.)		X
Front pedestrian awareness light (P.A.L.)		X
Keyswitch start	X	
Operator password start		X
Push button start with operator password		X
Single Pedal Inch Brake	X	
Push button park brake		X
Battery disconnect switch		X
System monitoring package	X	
Premium monitoring package		X
Seat switch activated engine, lights and display shutdown system		X
Signal activated engine shutdown system		X
Impact monitor with 30s shutdown		X
Impact monitor with immediate shutdown		X
Full underbody mesh belly pan		X
Greasing system for base truck		X
Optical fuel level sensor		X
Pressure fuel level sensor		X
2 front / 1 rear lifting eyes		X
Aftermarket-ready telemetry kit		X
Wireless access card reader		X
Wireless monitoring - cell	X	
Wireless monitoring - wifi		X
Wireless verification		X
PACKAGES	STD	OPT
Cool Truck package which includes belly pan including brake line protection, exhaust wrap, fans in hood key activated and rubber front axle guard		X
APPEARANCE	STD	OPT
Hyster yellow paint base truck	X	
Special paint colour		X
Special paint for full steel cab		X
Hazard warning striping on counterweight		X
SUPPLEMENTAL	STD	OPT
Literature pack		X
CE certification		X
12 Months / 2,000 Hours manufacturers warranty	X	
36 Months / 6,000 Hours extended warranty		X

Other options available through Special Products Engineering Department (SPED).
Contact Hyster for details.

STRONG PARTNERS. TOUGH TRUCKS.™

FOR DEMANDING OPERATIONS, EVERYWHERE.

Hyster supplies a complete range of warehouse equipment, IC and electric counterbalanced trucks, container handlers and reach stackers. Hyster is committed to being much more than a lift truck supplier.

Our aim is to offer a complete partnership capable of responding to the full spectrum of material handling issues: Whether you need professional consultancy on your fleet management, fully qualified service support, or reliable parts supply, you can depend on Hyster.

Our network of highly trained dealers provides expert, responsive local support. They can offer cost-effective finance packages and introduce effectively managed maintenance programmes to ensure that you get the best possible value. Our business is dealing with your material handling needs so you can focus on the success of your business today and in the future.



HYSTER EUROPE

Centennial House, Frimley Business Park, Frimley, Surrey, GU16 7SG, England.

Tel: +44 (0) 1276 538500



www.hyster.eu



infoeurope@hyster.com



[/HysterEurope](https://www.facebook.com/HysterEurope)





[@HysterEurope](https://twitter.com/HysterEurope)



[/HysterEurope](https://www.youtube.com/HysterEurope)



HYSTER-YALE UK LIMITED trading as Hyster Europe. Registered Address: Centennial House, Building 4.5, Frimley Business Park, Frimley, Surrey GU16 7SG, United Kingdom. Registered in England and Wales. Company Registration Number: 02636775.

©2020 HYSTER-YALE UK LIMITED, all rights reserved. HYSTER,  STRONG PARTNERS. TOUGH TRUCKS., MONOTROL and  are trademarks of HYSTER-YALE Group, Inc.

Kubota is a trademark of Kubota Corporation. Grammer is a trademark of Grammer Seating Systems Ltd.

Hyster products are subject to change without notice. Forklift trucks illustrated may feature optional equipment.